

User Manual

DNAKE Expansion Module

REMARK

Please follow the user manual for correct installation and testing. If there is any doubt please call our tech-supporting and customer center.

Our company applies ourselves to reformation and innovation of our products. No extra notice for any change. The illustration shown here is only for reference. If there is any difference, please take the actual product as the standard.

The product and batteries must be handled separately from household waste. When the product reaches the end of service life and needs to be discarded, please contact the local administrative department and put it in the designated collection points in order to avoid the damage to the environment and human health caused by any disposal. We encourage recycling and reusing the material resources.

CATALOG

PRODUCT FEATURE	1
TECHNICAL PARAMETER	1
PACKAGE CONTENT	2
OVERVIEW	1
BASIC SETTING	3
SYSTEM DIAGRAM	5
DEVICE WIRING	6
INSTALLATION	7
SAFETY INSTRUCTION	13
FCC Warning	14

PRODUCT FEATURE

1. High quality, IK07, IP 65
2. 10 Metal buttons (B17-EX001/S)
5 Metal buttons, 1 Nameplate Area (B17-EX002/S)
2 Nameplate Area (B17-EX003/S)
3. Nameplate and buttons with backlight (B17-EX001/S & B17-EX002/S)
Nameplate with backlight (B17-EX003/S)
4. Support surface and flush installation

TECHNICAL PARAMETER

Material: Aluminum

Power Supply: DC 12V

Rated Power: 1W

Standby Power: 1W

RS485: 2 (1 for input, 1 for output)

Dip switch: 4

Dimension: 188 × 88 × 34 mm

Working Temperature: -40°C to +55°C

Storage Temperature: -40°C to +70°C

Working Humidity: 10% to 90% (non-condensing)

PACKAGE CONTENT

MODEL: B17-EX001/S, or B17-EX002/S, or B17-EX003/S,

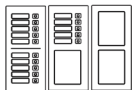

Module



Wiring Cover



Sealing Plug of
Wiring Port



Junction Pressing



PM2.5×6 (4 pcs)



Rear Cover



Screw Fixing Seat
(2 pcs)



PA4×30 (2 pcs)



PM4×20 (2 pcs)



FM3×4.5 (2 pcs)



Wrench Screw



Wires



Quick Start Guide

OVERVIEW

Model: B17-EX001/S

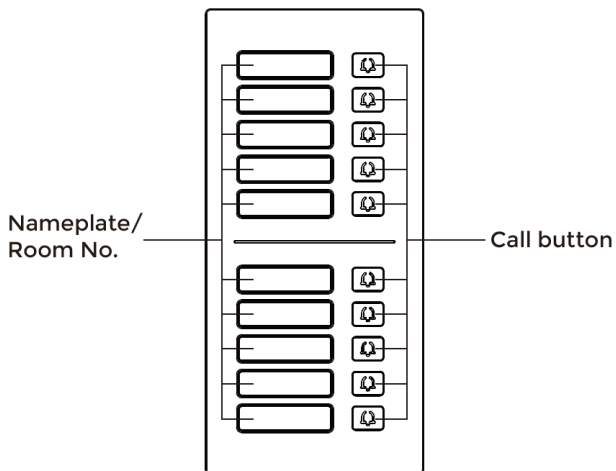

Model: B17-EX002/S

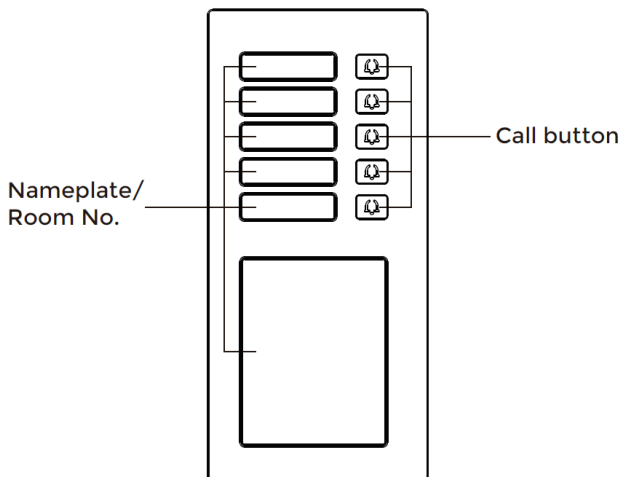

Model: B17-EX003/S

Nameplate/
Room No.

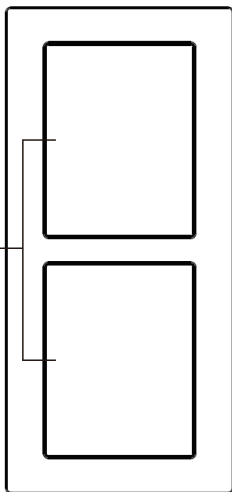

BASIC SETTING

Connect the door station and PC to a network switch in the same LAN. You can enter the IP address of the door station in the web browser search bar and log in with the default account (admin) and password (123456). This is where you can configure the device.

For getting the IP address, you can search by DNAKE Remote Upgrade Tool which is installed in the same LAN with the devices.

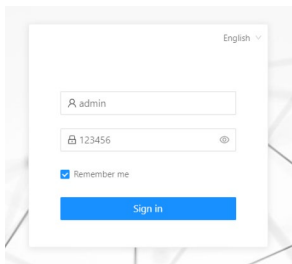

1. Basic configuration

Follow the instructions below to configure the module:

Step 1: Connect RS485 ports to door station and set the binary number nearby. If many modules are connected, make sure they have different binary number.

Step 2: Log in the door station's webpage to configure.

Step 3: Go to Access > Person. If persons are added, residents in Module page can be related with buttons.

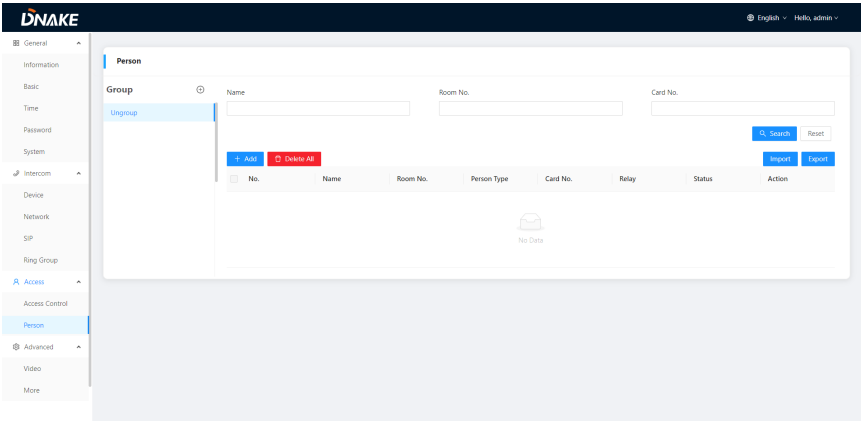

Step 4: Go to Advanced > Module. If persons are added, residents can be selected and room number will be filled in accordingly and locked. Room number can still be filled in without any resident.

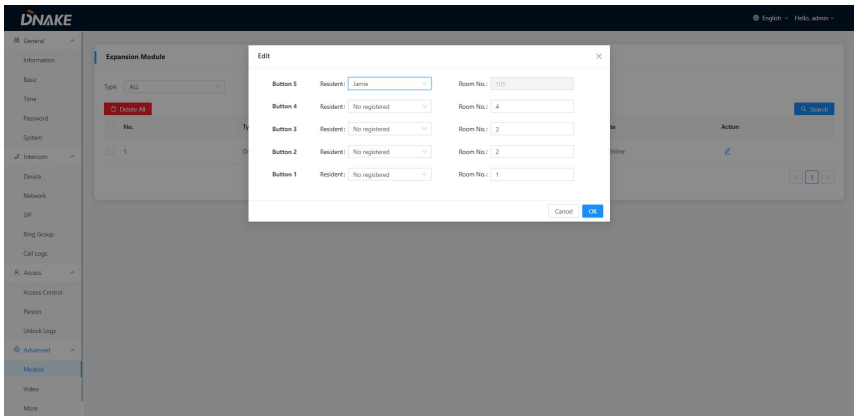

SYSTEM DIAGRAM

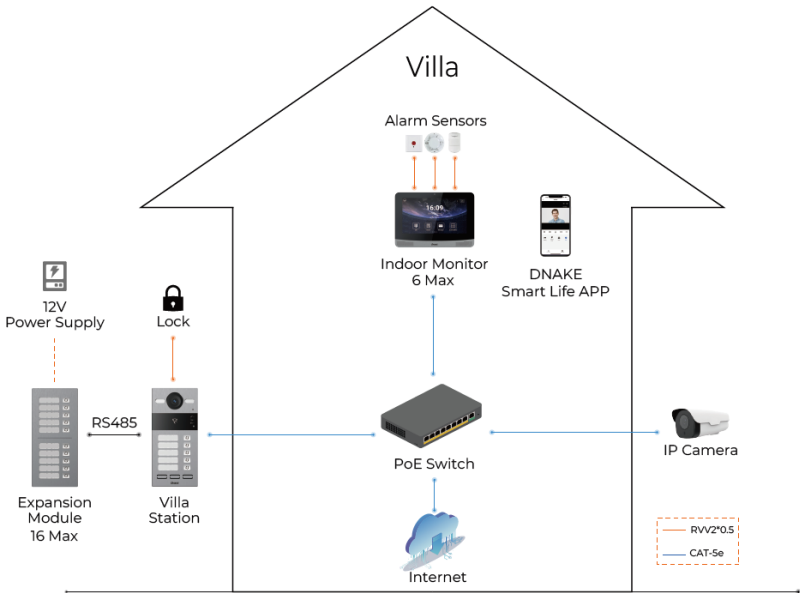

DEVICE WIRING

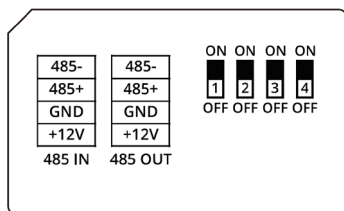

1. 485 IN

Connect the module to the door station or the previous module via RS485 ports.
Connect the power adapter to the module.

2. 485 OUT

Connect the module to the next expansion module.

3. DIP Switch

Set the module number from 00 to 15. Refer to the binary table below to set.

	0000	-	-	-	-
Device number	0	-	-	-	-
	0001	0010	0011	0100	0101
Device number	1	2	3	4	5
	0110	0111	1000	1001	1010
Device number	6	7	8	9	10
	1011	1100	1101	1110	1111
Device number	11	12	13	14	15

INSTALLATION

Installation of Wiring Cover

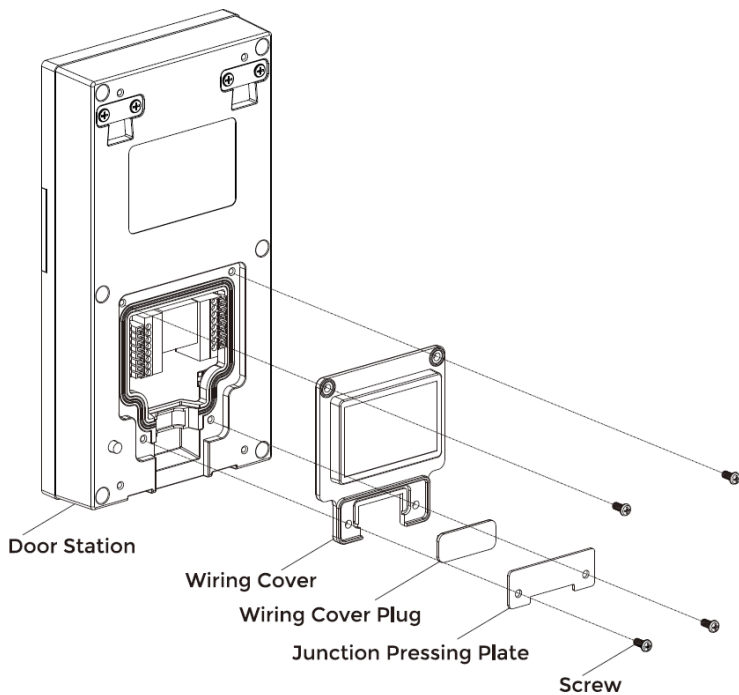

Surface Mounting-86 Mounting Box

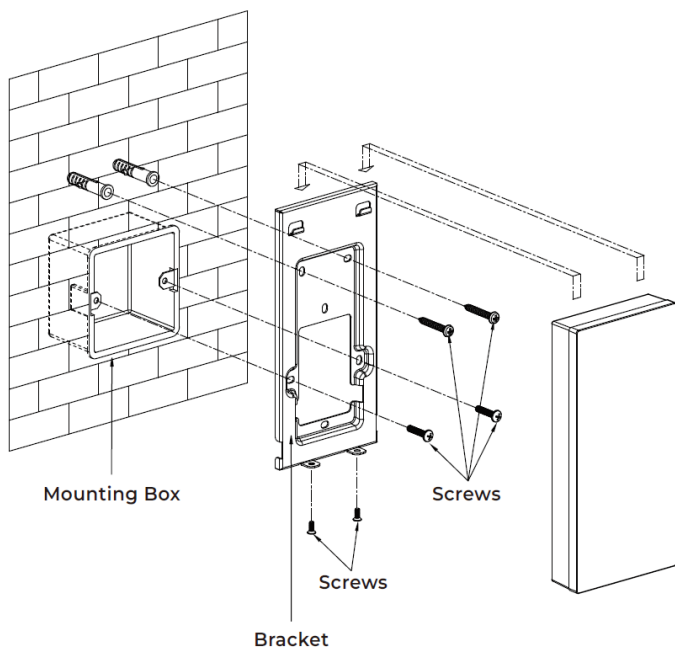

Product size: 88 × 188 × 32.5 mm
Surface Mounting size: 88 × 188 × 34 mm

Surface Mounting-118 Mounting Box

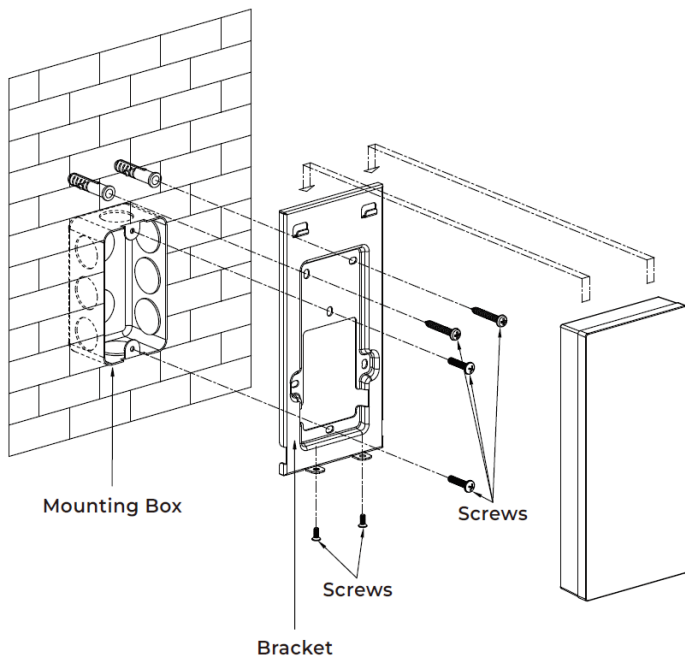

Product size: 88 × 188 × 32.5 mm
Surface Mounting size: 88 × 188 × 34 mm

Flush Mounting (Accessories required)

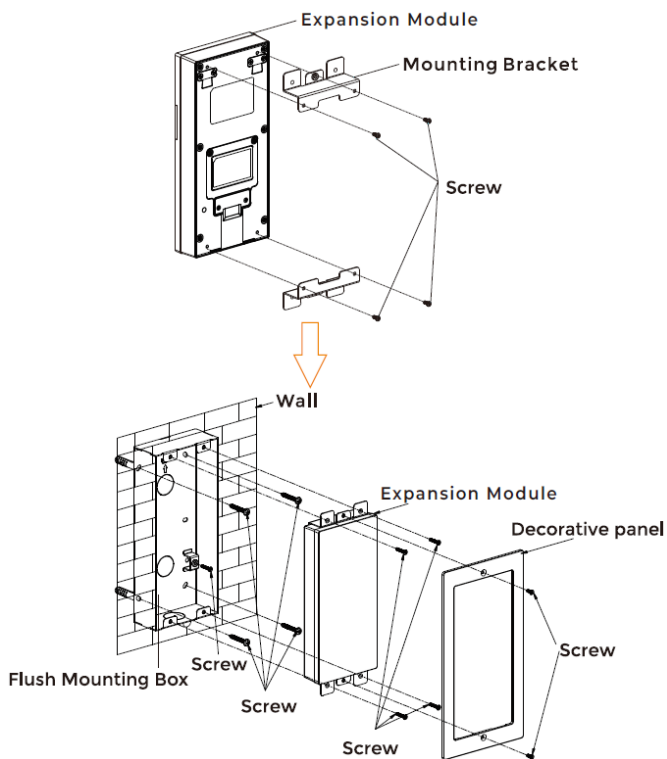

Product size: 88 × 188 × 32.5 mm
Flush Mounting size: 120 × 230 × 48 mm
Hole-cutting size: 98 × 219 × 42 mm

Flush Mounting (Accessories required)

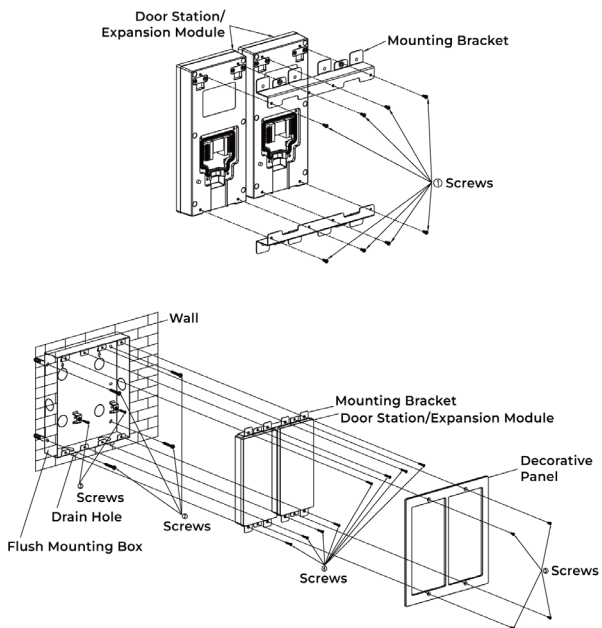

Product size: 88 × 188 × 32.5 mm
Flush Mounting size: 120 × 230 × 48 mm
Hole-cutting size: 195 × 219 × 42 mm

Flush Mounting (Accessories required)

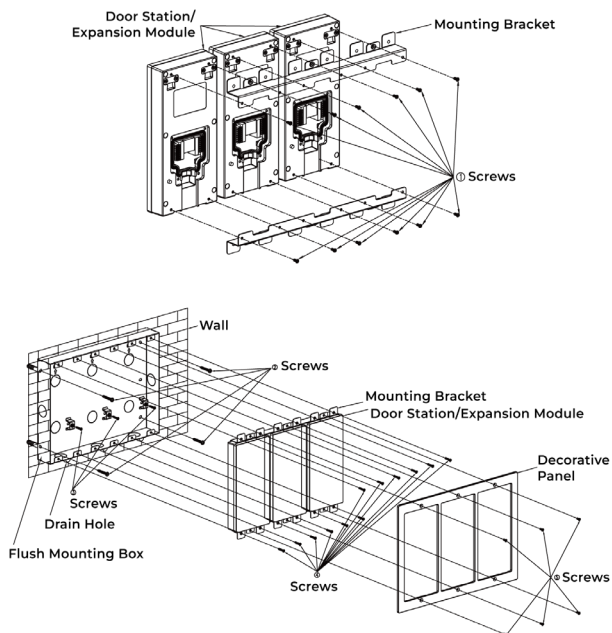

Product size: 88 × 188 × 32.5 mm
Flush Mounting size: 120 × 230 × 48 mm
Hole-cutting size: 291 × 219 × 42 mm

Tips:

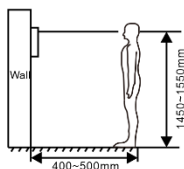

The camera should be 1450~1550mm above the ground.
The camera at this height can capture human face perfectly.

SAFETY INSTRUCTION

In order to protect you and others from harm or your device from damage, please read the following information before using the device.

- Do not install the device in the following places:
- Do not install the device in high-temperature and moist environment or the area close to magnetic field, such as the electric generator, transformer or magnet.
- Do not place the device near the heating products such as electric heater or the fluid container.
- Do not place the device in the sun or near the heat source, which might cause discoloration or deformation of the device.
- Do not install the device in an unstable position to avoid the property losses or personal injury caused by the falling of device.

Guard against electric shock, fire and explosion:

- Do not use damaged power cord, plug or loose outlet.
- Do not touch the power cord with wet hand or unplug the power cord by pulling.
- Do not bend or damage the power cord.
- Do not touch the device with wet hand.
- Do not make the power supply slip or cause the impact.
- Do not use the power supply without the manufacturer's approval.
- Do not have the liquids such as water go into the device.

Clean Device Surface

- Clean the device surfaces with soft cloth dipped in some water, and then rub the surface with dry cloth.

Other Tips

- In order to prevent damage to the paint layer or the case, please do not expose the device to chemical products, such as the diluent, gasoline, alcohol, insect-resist agents, opacifying agent and insecticide.
- Do not knock on the device with hard objects.
- Do not press the screen surface. Overexertion might cause floppover or damage to the device.
- Please be careful when standing up from the area under the device.
- Do not disassemble, repair or modify the device at your own discretion.
- The arbitrary modification is not covered under warranty. When any repair required, please contact the customer service center.
- If there is abnormal sound, smell or fume in the device, please unplug the power cord immediately and contact the customer service center.
- When the device isn't used for a long time, the adaptor and memory card can be removed and placed in dry environment.
- When moving, please hand over the manual to new tenant for proper usage of the device.

FCC Warning

This device complies with Part 15 of the FCC Rules. Operation is subject to the following two conditions:

(1) This device may not cause harmful interference, and (2) this device must accept any interference received, including interference that may cause undesired operation.

NOTE 1: This equipment has been tested and found to comply with the limits for a Class B digital device, pursuant to part 15 of the FCC Rules. These limits are designed to provide reasonable protection against harmful interference in a residential installation. This equipment generates uses and can radiate radio frequency energy and, if not installed and used in accordance with the instructions, may cause harmful interference to radio communications. However, there is no guarantee that interference will not occur in a particular installation. If this equipment does cause harmful interference to radio or television reception, which can be determined by turning the equipment off and on, the user is encouraged to try to correct the interference by one or more of the following measures:

- Reorient or relocate the receiving antenna.
- Increase the separation between the equipment and receiver.
- Connect the equipment into an outlet on a circuit different from that to which the receiver is connected.
- Consult the dealer or an experienced radio/TV technician for help.

NOTE 2: Any changes or modifications to this unit not expressly approved by the party responsible for compliance could void the user's authority to operate the equipment.

RF exposure statement

This equipment complies with the FCC radiation exposure limits set forth for an uncontrolled environment. This transmitter must not be co-located or operating in conjunction with any other antenna or transmitter.

 **EASY & SMART
INTERCOM SOLUTIONS**

 **DNAKE**